



Inter-Tenancy Barrier Systems

Horses for courses

The last few years has seen a rise in multi-unit residential design and construction, and with it an increasing popularity of inter-tenancy (IT) barrier systems to achieve superior noise attenuation and fire resistance between dwellings.

How an IT barrier system works

Central IT barrier systems come in many forms, such as aerated concrete, concrete tilt-slab, and plasterboard systems. The main advantage is that the Sound Transmission Class (STC) and Fire Resistance Rating (FRR) is substantially achieved by a heavy central barrier between frames, leaving the unit linings conventional. Depending on the central barrier type, several internal lining service penetrations can often be permitted, without the need for complex fire-stopping or acoustic treatment.

Fixings that fail in a fire, such as aluminium clips, connect the central barrier to the frames either side. In the case of a fire in one unit, the clips on the affected side fail, allowing that unit to detach, whilst the protective central IT barrier remains connected to the adjacent unit.

A central IT barrier system was put to a real-life fire test at Hobsonville Point Auckland, September 2017. The

picture below shows the substantial fire and collapse of the structure on the right, whilst part of the building on the left remains standing, protected by a central barrier vertical fire separation.



FIGURE 1: Hobsonville Point Fire, September 2017

Central barrier and conventional double frame systems

In contrast, a more traditional double frame IT wall system requires heavier and/or multiple internal apartment linings to create the mass required to

meet STC and FRR performances. These linings protect the framing behind, and to maintain their integrity tested and verified service penetration seals must be installed.

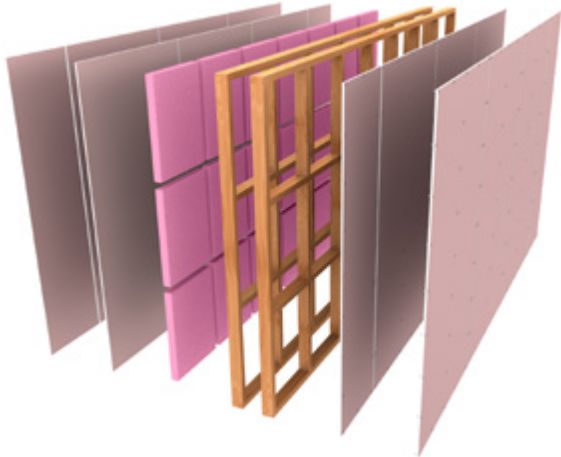

FIGURE 2: Double timber frame IT wall system, heavy unit linings, penetrations sealed

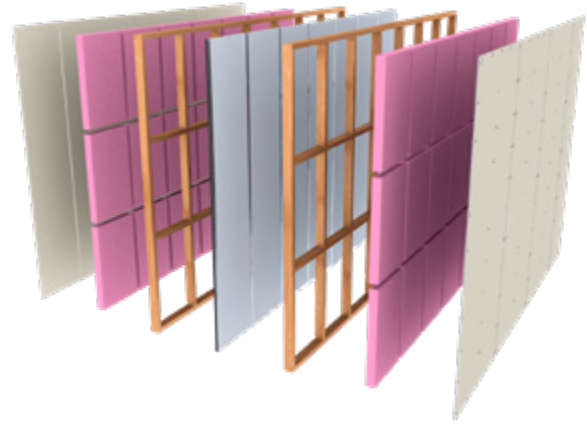

FIGURE 3: Central barrier IT wall system, conventional unit linings, some penetrations permitted

Horses for courses

It must be remembered that central IT barrier systems have been developed to provide vertical separation

between units and are ideally suited for Terrace Home applications. Difficulties can arise when IT barrier systems are specified in multi-level apartment construction where horizontal separation is also a requirement.

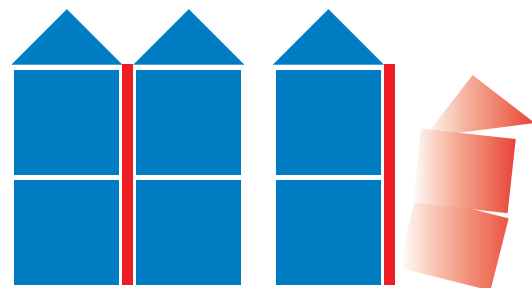

FIGURE 4: IT Barrier Systems are ideal for Terrace Homes. The central barrier remains attached to the non-fire side. Loadbearing members of the fire-affected unit can fail.

In framed multi-unit and multi-level construction, the loadbearing members of lower apartments must remain intact during a fire to avoid fire spread and progressive collapse. This means that the lower loadbearing frames require heavier protective linings and that any service

penetrations must be fire-sealed. In this case central IT barrier systems with conventional apartment linings do not work, and it would be more cost-effective to revert to a traditional IT wall configuration, such as a double frame system.

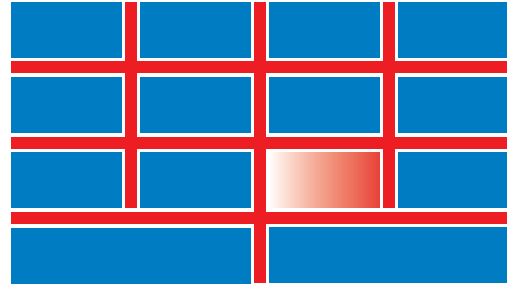

FIGURE 5: Use IT Barrier Systems with care in multi-level apartments. Conventional double frame IT systems might be more efficient. Loadbearing members of the fire-affected unit must remain intact.

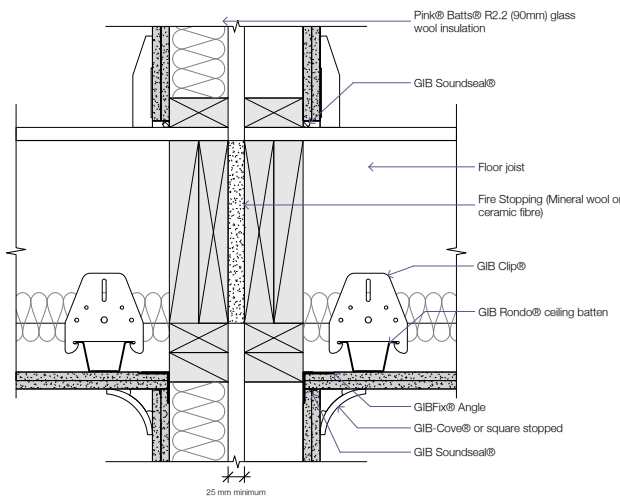

FIGURE 6: Double frame in multi-level, linings protect lower loadbearing frames

Figure 6 illustrates how a traditional double frame system is used in multi-level apartment construction. If we were to substitute a central IT barrier system, then lower loadbearing frames must also remain fully protected with heavier linings. In addition to fire protection, the lower apartment linings assist with achieving required noise attenuation and minimise potential noise ‘flanking’ via the structure. The need for lower frame protection largely negates the benefits of a central IT barrier system.

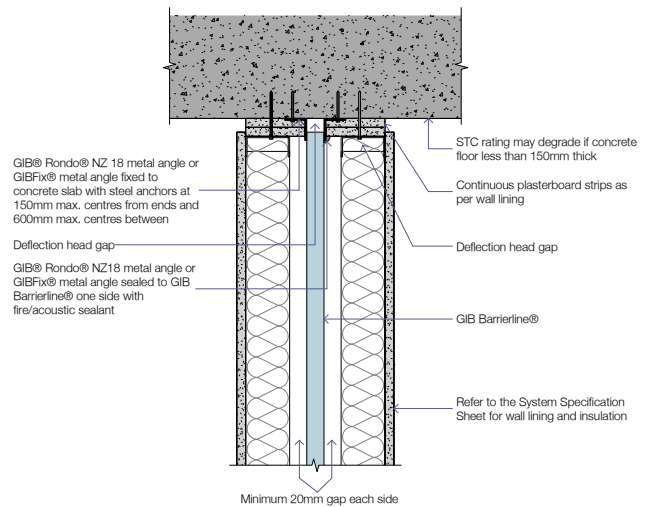

FIGURE 7: IT barrier in multi-level, separate structure supports floors above frames

Figure 7 gives an example where IT barrier systems can be successfully used in multi-level apartment construction. In this case a separate structure supports the higher floors and the apartment IT walls are non-loadbearing elements providing vertical fire and noise separation.



Final words

Carefully consider what IT system best suits your needs. Central IT barrier systems are ideal for Terrace Home applications, whilst traditional double frame systems might be the better option in multi-level apartment construction depending on the structural system selected.

Sources for further information include;

GIB® Noise Control Systems, 2017

gib.co.nz/systems/gib-noise-control-systems/

GIB® Fire Rated Systems, 2018

gib.co.nz/systems/gib-fire-rated-systems/

New Zealand Wood Design Guides

nzwooddesignguides.wpma.org.nz/home/

For further information go to gib.co.nz or call the GIB® Helpline on 0800 100 442.