

Blisters in Tape

Description

- Bubbles appear in areas of the paper jointing tape (ranging in size from approximately 10mm to 40mm, or more)

Remedy

- Slit tape to open up blistered area
- Fill out with compound, then press tape back in place with broad-knife
- When dry, smooth to level finish

Cause

- Insufficient compound used under tape
- Tape not initially pressed into good contact with compound
- Too much compound forced from under tape by excessive tool pressure when embedding
- Not enough compound in recess
- Compound gauge is too dry

Prevention

- Provide sufficient compound under entire tape – 0.8mm

Centre Cracking

Description

- Cracks appear in the joint down the centre of the joint tape

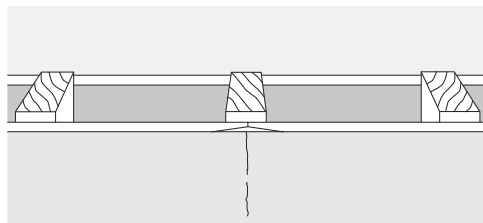

Remedy

Relieve stress, i.e. providing adequate isolation by installing a control joint and re-taping, then feathering compound over broad area to disguise build-up

Cause

- Abnormal stress build-up resulting from structural deflection or racking
- Excessive stresses resulting from hygrometric and/or thermal expansion and contraction

Prevention

- Correct unsatisfactory environmental conditions
- Provide sufficient relief and re-tape
- Provide proper isolation from structure to prevent stress build-up
- Provide adequate control joints
- Structurally brace underlying framing
- Ensure moisture content of timber is 18% or less

Joint Darkening

Description

- A dark area occurs in the area of the joint commonly as a result of set compound being darker than dried compound

Remedy

- Redecorate after joints are thoroughly dry

Cause

- Occurs most commonly with colour-tinted paint rather than white. Most severe when applied in humid weather or when joints have not fully dried

Prevention

- Be sure joints are thoroughly dry before painting

Edge Cracking

Description

- Cracks at edge of GIB® tape or GIB® Goldline® trims

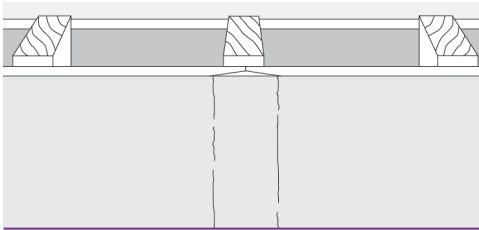

Remedy

- Remove all poorly bonded tape, then reapply compound and tape in correct manner

Cause

- Fast drying of taping compound due to high temperature and low humidity, or excessive drafts
- Improper application, e.g. over-dilution of compound, use of wrong compound, or no second coat over tape
- Cold, wet application conditions (also causes poor bond)

Prevention

- In hot, dry conditions, use GIB Tradeset® 45
- In extreme conditions use a multi-purpose air drying compound. **Note:** these dry rather than set, so provide more open time
- Place shielding devices over room openings to prevent drafts. Do not apply joint treatment over hot surfaces
- During cold weather, control heat at minimum 10°C and supply good ventilation
- Avoid practices listed under “Cause” opposite

Excessive and/or Delayed Shrinkage

Description

- Shrinkage that occurs after longer time periods or is unusually high

Remedy

- See ‘starved joints’ (p. 108)

Cause

- Atmospheric conditions – slow drying and high humidity
- Insufficient drying time between coats of compound
- Excessive water added in mixing compound
- Excessive compound depth
- Combinations of the above

Prevention

- Ensure that each coat of compound is properly dry before applying the next. Ensure a minimum temperature of 10°C is maintained during application and drying of compounds

| Shadowing | |
|---|--|
| <p>Description</p> <ul style="list-style-type: none"> Shows as a build-up of dust, typically once the wall has been decorated | <p>Remedy</p> <ul style="list-style-type: none"> Wash painted surfaces with warm water and redecorate surface if necessary |
| <p>Cause</p> <ul style="list-style-type: none"> Temperature differentials in outside walls or top floor ceilings cause airborne dust to collect on colder condensation spots of interior surface | |
| Starved Joints | |
| <p>Description</p> <ul style="list-style-type: none"> Joint area is under filled in relation to the surrounding plasterboard | <p>Remedy</p> <ul style="list-style-type: none"> Reapply a full coat of compound over tape. Since this is the thickest application most shrinkage occurs in this coat, making it easier to fill taper properly. Finish by standard procedure |
| <p>Cause</p> <ul style="list-style-type: none"> Delayed shrinkage caused chiefly by insufficient drying time between coats of compound Insufficient compound applied for second taping coat to fill joint recess/taper. Shrinkage usually progresses until drying is complete Over-thinning compound, particularly with boxes | <p>Prevention</p> <ul style="list-style-type: none"> Allow each coat of compound to dry thoroughly before applying succeeding coat, or use a low-shrinkage setting compound such as GIB Tradeset® or GIB Lite Blue® |
| Finish Gloss Variation | |
| <p>Description</p> <ul style="list-style-type: none"> Variations in gloss level of paint between the plasterboard and joint area | <p>Remedy</p> <ul style="list-style-type: none"> Allow to 'age' for 3–4 weeks then redecorate. Ensure that the paint is roller applied |
| <p>Cause</p> <ul style="list-style-type: none"> Differences in suction of the board paper and joint compound. Problem accentuated by strong side lighting with slight angle of incidence to ceiling or wall surface. May also be chemical incompatibility of joint compounds and paint system | <p>Prevention</p> <ul style="list-style-type: none"> Before painting with high gloss paint, apply skim coat of compound over entire surface (or use a spray on skim coat system) Consider where critical lighting is coming from and move if possible |

Paint Sheen Variation

Description

- A differential in gloss levels over the whole area of the wall. This variation can be greater on nail holes and joints, and is highlighted by the use of semi and full gloss paints

Remedy

- Sand back and allow joint compound to fully dry before applying a sealer coat. Then apply correct paint system as per the manufacturer's instructions

Cause

- Nail holes and joints not sealed and undercoated correctly
- Joint compound not fully dry before paint application
- Burnish marks caused by rubbing or washing the wall
- Incorrect sealer used which does not equalise surface absorption of paper and compound

Prevention

- Use correct paint system and apply as per manufacturer's instructions

High Crowns

Description

- Joint area is higher than the surrounding plasterboard and may result in shadowing across the joints

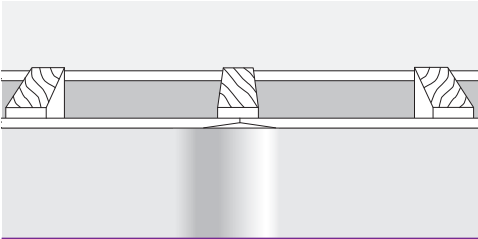

Remedy

- Sand joints to flush surface (take care to avoid scuffing paper or joint tape by over-sanding)

Cause

- Excessive compound over joint
- Compound not feathered out beyond shoulders
- Improper bedding of tape
- Framing out of alignment or sheet edges not tight against framing
- Improper adjustment of mechanical tools
- Misuse of, or worn, tools

Prevention

- Embed tape properly, using only enough compound to cover tape. Adequately feather compound

Tram Lines/Tracks

Description

- Shrinkage of the joint adjacent to the paper tape. Looks like the tape is visible on the joint

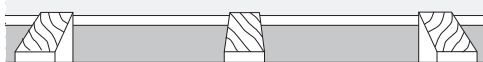

Remedy

- Lightly sand affected areas
- Apply a skim coat to the joint with an air drying compound, and sand and decorate

Cause

- The first coat of compound is not sufficiently dry before the second coat is applied. When the first coat dries it shrinks and pulls the tape back into the joint
- The second and top coat are too thin
- Compound is too thin or watery
- Inadequate drying between coats
- Poor drying conditions
- Slow drying due to excessive filling in one coat
- Premature paint application

Prevention

- Allow joint compound to fully dry between coats

Trim Defects

Description

- Cracks appearing at the edge of GIB® Goldline® Platinum trims

Remedy

- Remove all poorly bonded trims and reapply compound and trims as recommended

Cause

- Taping compound drying too fast, due to high temperatures and low humidity (or excessive drafts) or not enough compound
- Improper application, such as over-dilution of compound, use of wrong compound, excessive compound under tape, or no second coat over tape
- Cold, wet application resulting in poor bond

Prevention

- Do not install at temperatures below 10°C. During cold weather, control heat at a minimum 10°C and supply good ventilation. In hot, dry conditions, place shielding devices over room openings to prevent drafts. Do not apply joint treatment over hot surfaces. Lightly wet down floors if room humidity is too low
- Avoid practices listed under “Causes” opposite

Nail/Screw Pops

Description

- Protrusions or bumps directly over the nail/screw head
- Rupture of the surface around nail/screw head
- Looks like nail/screw head protruding above the surface of the board

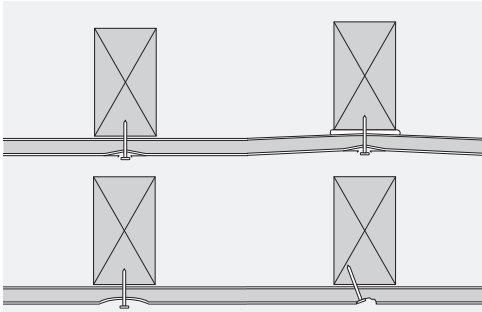

Remedy

- Nail pops that occur after at least one month's heating cycle are probably caused by timber shrinkage. Because further shrinkage is likely to occur and pops reappear, do not repair until the end of a heating season
- A screw should be reapplied 50mm from the popped fastener. Drive in a new fastener whilst applying firm pressure, to ensure firm contact with framing. Use a nail punch to seat the popped fastener beneath the surface of the plasterboard
- Remove compound. Apply two coats of setting compound followed by an air dry compound coat, then redecorate

Cause

- Timber shrinkage (timber shrinks as it dries, causing the fastener to protrude). Nail/screw pops may not become apparent for some considerable time after installation
- Fixing through glue – if screws or nails are applied through adhesive, a pop can occur as the glue dries and shrinks back; pulling the plasterboard closer to the framing member
- Plasterboard not held in close contact with the framing members. If the plasterboard is not held firmly against the stud while fixing, it increases the possibility of over-driving the nail (resulting in a blister-like defect the size of the hammerhead)
- Overdriven or skewed nails/screws can puncture the face paper, which results in no holding power
- Air trapped between the fixture and the compound, when the compound is placed
- Nail heads/screw heads puncturing face paper

Prevention

- Avoid timber shrinkage by using GIB® Rondo® metal ceiling battens for ceilings or kiln dried timber. Close in the building and protect the framing from the elements as soon as possible. Ensure that timber moisture content is 18% or less at the time of lining. Use of steel battens for large ceiling areas will eliminate shrinkage factors
- Fixing through glue – for walls, use nails/screws around the perimeter and GIBFix One® or GIBFix® All-Bond adhesive in the centre of the sheet. No mechanical fastener should be within 200mm of an adhesive daub. Never nail/screw through glue
- Plasterboard not in close contact with the framing members – when fixing ceilings, fix the centre of the plasterboard first. In all cases hold the plasterboard firm against the framing member whilst fixing
- Drive nails/screw in straight so they are neatly seated slightly below the surface of the sheet
- Apply compound in critical light areas by pressing the compound into the fixings, rather than trowelling it on. This removes trapped air

Peaking

Description

- A condition where joints are visible under critical lighting
- More prevalent when board has been installed in cold weather
- Often called ridging or beading
- Looks like a continuous ridge along the length of the joint, with a uniform peak-like pattern at the centre
- Commonly occurs in conjunction with 'nail popping'

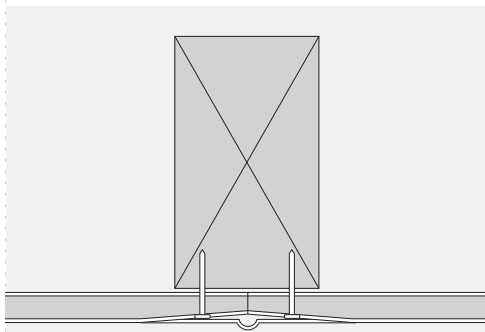

Remedy

- Ridges must only be repaired after a full heating cycle (6 months to a year). Mid-summer is generally the best time for rectifications
- Apply a coat of setting compound over the joints using a 300mm trowel to widen the joint. Scrape back and apply a light coat of a topping coat. Reseal affected area. Examine the surface with harsh lighting to determine whether the ridge has been concealed. If all right, then decorate

Cause

- Excessive gaps (i.e. over 2mm) left between sheets
- Timber movement due to excessive moisture content of timber at time of lining and subsequently drying out. This is more prevalent with 10mm plasterboard than thicker plasterboards
- No gaps at the base of wall sheets. This can cause pressure on the base of the sheets thus transferring tension to the joints
- Inadequate ventilation with concrete floor slabs, resulting in a build-up of water vapour

Prevention

- Use GIB® Rondo® metal ceiling battens on ceilings
- Ensure timber framing moisture content is 18% or less at time of lining
- Use a back blocking system on ceilings
- Gaps between sheets should be pre-filled with a setting compound and allowed to completely dry before application of tape and subsequent coats of compound
- Always allow a 5mm-10mm gap at the base of wall sheets to allow for shrinkage of the wall plates and studs
- Ensure compound materials are maintained at a minimum temperature of 10°C during, and following, installation. Allow adequate ventilation

Peeling/Flaking, Severe Cracking

Description

- Large flakes that adhere loosely to the surface
- This problem is an extension of cracking and the causes and remedies are the same

Shrinkage

Description

- Compound shrinking back when it dries, causing a depression at the joint or on a fastener
- Looks like depressions at the joint

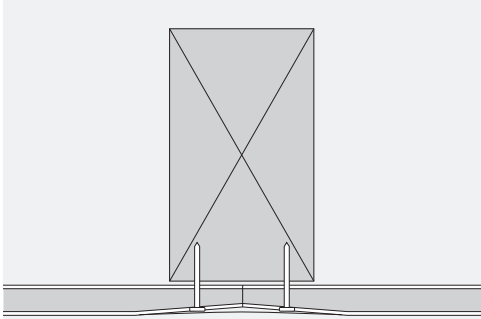

Remedy

- Lightly sand affected areas and apply air drying compound, then sand (using 220 grit or finer sand paper)
- Seal repaired areas and then re-decorate

Cause

- Compound too thin or watery
- Inadequate drying between coats
- Slow drying due to excessive filling in one coat
- Under slow drying conditions, joints and plasterboard may hold moisture for weeks

Prevention

- Provide proper drying conditions for compound. The two setting coats must be thoroughly dry prior to top coating. The top coat must be thoroughly dry prior to application of sealer
- Use compound at heaviest workable consistency and allow to stand for 2–3 minutes before applying
- In slow drying conditions apply a number of thinner coats rather than a few thick coats
- Under slow drying conditions use shorter set time joint compounds
- Allow joint compound to fully dry between coats

Paint Checking/Cracking

Description

- Small splits or star shape cracks on paint film surface

Remedy

- Remove paint allow joint compound to fully dry, repair any damage and reapply paint (as per manufacturer's instructions)

Cause

- Joint or topping compound not fully dry before paint application
- Paint not fully dried before next application
- Paint applied too thick
- Incorrect paint used

Description

- Plasterboards are not flat but have a bowed, dished or undulating surface
- Studs or ceiling joists not on the same plane as other framing members
- A twisted framing member
- Shadows being cast across the joint
- Plasterboard forced into place

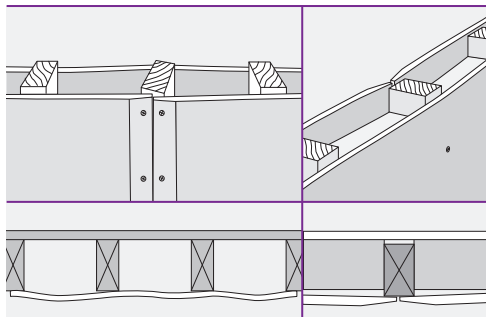
Remedy

- It is extremely difficult to rectify some of these problems without having to resort to full replacement of the linings after rectifying underlying factors
- Replace all warped or crooked studs

Cause

- Framing oversights
- Framing out of alignment with adjacent framing, making it difficult to bring the sheet into firm contact with framing members
- Excessive moisture in the timber framing can also cause warping, twisting or bowing as it dries
- Fixing the perimeter of the sheet prior to the centre
- Fixing of damp plasterboard
- Excessive loading from insulation or light fittings causing too much weight on plasterboard
- Incorrect placement of vapour barrier causing moisture build-up within the plasterboard
- Exceeding maximum span of fasteners when fixing
- Not allowing a 5mm–10mm gap between the floor and the plasterboard
- Incorrect fastening sequence for lining light gauge steel framing
- High temperatures in the ceiling space causing board expansion, particularly in skillion roofs with poor ventilation
- Incorrect storage – storing of plasterboard on edge on damp concrete floors

Prevention

- Timber members must be brought into alignment
- Check stud, batten and joist alignment, correcting wherever necessary
- Always fix from the centre outwards
- Sheets must be touch fitted and not forced into place

Fibre Raise Adjacent to Joint Areas

Description

- A shadow adjacent to the stopped area

Prevention

- Lightly sand between all coats

Cause

- Commonly encountered with spray applied sealer and top coats which have not been lightly sanded back between coats
- Also common where alkyd sealers are used and not sanded back before the application of top coats
- Excessive sanding of paper raising fibres

Compound Defects

Grit

- Small pieces of raw material or contaminant that show up when the compound is trowelled

Shrinkage

- The compound shrinks back into the joint when it dries. Caused by thick coats of compound, not allowing the compound to dry between coats and using incorrect mixing ratios

Seeding/Lumps

- Small lumps of hard compound that can form towards the end of a compounds working time. Can be due to contamination, over mixing, dirty tools, or particles of dry compound left in the mixing bowl

Inconsistent Set Time

- Setting compounds having a different set time to those stated on the bag. There are a number of probable causes including contamination, particles of dry compound left in the mixing bowl, variable water temperature, over mixing and re-working, as well as inappropriate product storage

Board Defects

Delamination

- Separation of the paper ply from the main body of the paper. Paper still adhered to the core with weak inter-ply bond.

Peeler

- Paper liner coming away cleanly from the core with no paper adhesion. Caused by calcinated (over dried) board. Also occurs when the plasterboard is damp

End Split

- Peeling or splitting 50mm–100mm from end of sheet
- Usually caused by soft board at the knives during the manufacture of plasterboard

Shoulder

- The thickness of the board at the inner edge of the taper is greater than that in the body of the board itself

Cupped or Hooked Edges

- Scalloped or hooked. Taper does not have regular profile
- Can be caused during manufacture or incorrect storage of the board edge on damp concrete surfaces

Soft Edges

- Soft core or calcinated due to over drying of the edge
- Damp due to storage on damp concrete surfaces

Blisters

- Intermittent splitting of the core and paper